

GPS Antenna Converter



The GPS antenna combines a planar antenna and a frequency converter, which translates the high-frequency phase-modulated spread spectrum signal of the GPS system to an intermediate frequency. This way a standard cable (e.g. AWG22) can be used for the connection with the GPS clock and a distance of up to 120 meters between receiver and antenna is possible without additional amplifier.

Key Features

- 12-channel simultaneous operation
- Ultra-low power consumption: less than 1W
- Holder for Wall Mounting (included)

Interface Characteristics

- **Cable:**
 - 1 Pair 22 AWG Shielded Cable
- **Power consumption:** less than 1 W
- **Passive current loop system**
- **DCF 77 transmission format**
- **Acquisition:** less than 4 minutes

Performance Specifications (GPS system)

- **General:**
 - L1 (1575.42 MHz) frequency
 - C / A code
 - 12-channel continuous tracking receiver
- **Update rate:** 1 Hz
- **Accuracy:**
 - Horizontal: < 2.5 m (50%), < 5 m (90 %)
 - Altitude: < 5 m (50%), < 8 m (90 %)
 - Velocity: 0.06 m / s
 - PPS (static): ± 25 ns (50 %)
- **Acquisition time:**
 - Re-acquisition: 2 s (50 %)
 - Hot Start: 2 s (50%)
 - Warm Start: 35 s (50%)
 - Cold Start: 38 s (50%)
- **Operational limits:**
 - Altitude: 18000 m
 - Velocity: 515 m / s
 - Acceleration: 2 g
- **Sensitivity:**
 - Tracking: - 160 dBm
 - Acquisition: - 146 dBm

Environmental Specifications

- **Operating Temperature:** - 40 °C to + 85 °C
- **Storage Temperature:** - 55 °C to + 105 °C
- **Vibration :**
 - 0.008 g² / Hz from 5 Hz to 20 Hz
 - 0.05 g² / Hz from 20 Hz to 100 Hz
 - - 3 dB / octave from 100 Hz to 900 Hz
- **IP code:** 65

NB : the unit is remotely powered by the connected GPS receiver (via the antenna cable) and can be used only with GPS equipment from GORGY TIME.

Please specify your order, if you need a different cable length.

VERSION	ITEM CODE
GPS antenna converter unit with a 25m cable	3G25-V4
GPS antenna converter unit with a 50m cable	3G50-V4
GPS antenna converter unit with a 100m cable	3G100-V4



GPS ANTENNA

Professional quality L1 GPS antenna placed in a compact and conical housing.

The antenna features a custom high performance broadband patch element, a 40dB gain LNA stage and an out-of-band high rejection SAW filter. Equipped with a sharp SAW pre-filter to provide strong protection against out-of-band signals. It offers a bandwidth of ± 10 MHz centered on 1575.42 MHz. It offers a large axial ratio, excellent reception of circularly polarized signals, good multipath rejection and high out-of-band rejection.

Key Features

- **Weight:** 0.15 kg
- **Dimensions:** 65.5 mm x 21 mm (d x H)
- **Colour:** white
- **Shape:** conical

Mechanical characteristics

- **Vibration:** 3 axis, sweep = 15 min, sweep from 10 to 200 Hz: 3 g
- **Shock:** vertical axis: 50 g, each axis: 30 g
- **Ratio axis:** 4dB at 90°
- **Bracket:** in L or in tube

Environmental characteristics

- **Requirements:** RoHS, REACH, and RED
- **Operating temperature:** -40°C to + 85°C
- **Storage temperature:** -45°C to +85°C
- **Humidity/Salt fog:** MIL-STD-810F Section 509.4
- **Waterproof:** IP67

FASTENING KIT INCLUDING

- 1 hollow tube of 20cm length
- 1 plate
- 2 screws of 28 mm
- 2 screws of 62 mm
- 2 nuts
- 2 washers

Electrical characteristics

- **Frequency band:** L1 1575MHz \pm 10MHz
- **Polarization:** RHCP
- **Amplification gain (LNA):** 39 dB min.,
- **Flatness gain:** +/- 2 dB, 1559 to 1606 MHz
- **Out-of-band discharge:**
f < 1560 MHz: >50 dB
f > 1600 MHz: >50 dB
f > 1620 MHz: >70 dB
- **VSWR output:** <1.5:1 typ. 1.8:1 max
- **Maximum noise:** 3 dB
- **DC Voltage:** 2,5 to 16 VDC nominal (max. 12VDC recommended)
- **Direct current:** 15 mA typ.
- **ESD Protection circuit:** 15 KV air discharge



HARDMOUNT GPS ANTENNA



Hardmount Antenna provides a permanent-mount antenna. Housed in a compact, low-profile package, the Hardmount Antenna is well-suited to mobile positioning applications.

The Hardmount Antenna is a miniature patch antenna with a 25 dB preamplifier. The antenna is designed for installation on vehicles with a 19mm mounting hole.

The antenna comes complete with gasket and mounting nut. May be installed on flat surfaces up to 2.5mm thick.

Hardmount Antenna Technical Data

- **Weight:** 6.4 oz. (180g)
- **Dimensions:** 2.48 inch dia. x 1.6 inch ht. (63mm dia. x 40.5 mm ht.)
- **Connector:** TNC
- **Mounting:** 0.75 inch threaded mount
- **Operating Temp:** -40°C to + 85°C
- **Storage Temp:** -40°C to + 100°C
- **Prime Power:** 4.75 V (+.5 V)
- **Humidity:** 20% to 95% R.H.
- **Waterproof:** Submersible to 1 meter
- **Frequency:** L1 (1575) MHz
- **Power Consumption:** 40mA max
- **Impedance:** 50 OHMS
- **Polarization:** RHCP
- **VSWR:** 2.0 max
- **Vibration:** 10~200 Hz. Log. sweep 3
- **Axial Ratio:** 90° : 3.0 dB min. 20° : 6.0 dB min
- **Gain:** 28.0 dB min
- **Noise:** 2.0 dB max (+23°C) 2.5 dB max. (+80°C)

FASTENING KIT IS INCLUDING

- 1 plate





Multi-constellations ANTENNA

The high gain precision GNSS antenna covers the BeiDou B1, Galileo E1, GPS L1, GLONASS L1 and SBAS (WAAS, EGNOS, QZSS & MSAS) frequency bands (1557 to 1606 MHz). They use circularly polarized signal reception technology over the entire bandwidth of the antenna.

The antenna is equipped with a three-stage low noise amplifier, including a feed input LNA, a mid-section SAW to filter the combined output, and a final output gain stage. The antenna has an additional pre-filter to provide additional protection against near-frequency and strong harmonic signals. The antenna is housed in a permanently mounted metal base with two nickel-coated nuts and a weatherproof case.

Key Features

- **Weight:** 0.15 kg
- **Dimensions:** 65,5 mm x 21 mm (D x H)
- **Bandwidth (2dB):** 47 Mhz
- **Coulour:** White
- **Shape:** Conical

Mechanical characteristics

- **Vibration:** 3 axis, sweep = 15 min, sweep from 10 to 200 Hz: 3 g
- **Shock:** Vertical Axis: 50 g, each axe: 30 g
- **Ratio axis:** <2 dB typ., 3 dB max.
- **Mounting:** Permanent 3/4" (19mm) through-hole mounting
Bracket: in L or in tube

Environmental characteristics

- **Requirements:** RoHS, REACH, et RED
- **Operating temperature:** -40°C to + 85°C
- **Storage temperature:** -45°C to +85°C
- **Humidity/Salt fog:** MIL-STD-810F Section 509,4
- **Waterproof:** IP67

KIT D'ATTACHE INCLUANT

- 1 tube creux de 20cm de long
- 1 plaque
- 2 vis de 28 mm
- 2 vis de 62 mm
- 2 écrous
- 2 rondelles

Electrical characteristics

- **Frequency band:** 1559 to 1606 MHz
- **Polarization:** RHCP
- **Amplification gain (LNA):** 40 dB min.,
- **Flatness gain:** +/- 2 dB, 1559 à 1606 MHz
- **Out-of-band discharge:**
f < 1500 MHz : >50 dB
f > 1640 MHz : >70 dB
- **VSWR output:** <1.5:1 typ. 1.8:1 max
- **Maximum noise:** 3 dB typ.
- **Main power:** 2,5 to 16 VDC nominal (max. 12VDC recommended)
- **Direct current:** 19 mA typ.
- **ESD Protection circuit:** 15 KV air discharge



PATCH ANTENNA

The Miniature GPS Antenna is a water-resistant, low-profile antenna. It has a magnetic mounting for quick, convenient placement on or inside vehicles, making it ideal for mobile asset management and embedded board products.



Key Features

- **Mounting:** Magnetic Mount - waterproof IP67
- **Impedance:** 50 ohms
- **Frequency:** 1575.42MHz
- **Input voltage:** 3V or 5V (20mA at 3V)
- **Polarization:** RHCP
- **VSWR:** 2.0 max
- **Gain:** 27dB at 5V
- **Cable:** RG174
- **Connector:** SMA
- **Dimension (L x W x H):** 37.4mm x 34mm x 12.95mm
- **Provided with 5 m cable**



Lightning Surge Arrester

Both connector ports of this unit are equally protected. This provides protection no matter which way it is installed. Either port can face the antenna and either port can face the equipment.

Mechanical characteristics

Components

- Centre contact
- Outer contact
- Other metal parts
- Crimp ferrule
- Insulator
- Gasket

Materials

- Copper alloy
- Brass
- PTFE
- MVQ, NBR

Environmental Specifications

- Operating temp.: -40°C / +85°C
- Protection class: IP 67 (IEC 60529)

Electrical characteristics

- Impedance: 50 Ω
- Frequency: DC...6 GHz
- Return loss: > 20 dB
- Breakdown voltage: 150...250 V DC (100 V/s)
- Impulse discharge current:
 - 8/20 μs, 5 kA 10 times / 10 mal
 - 8/20 μs, 10 kA 1 time / 1 mal
- Max. power: 25 W
- Residual pulse energy:
 - typ. 400 μJ (4kV, 1.2/50 μs; 2kV, 8/20 μs)

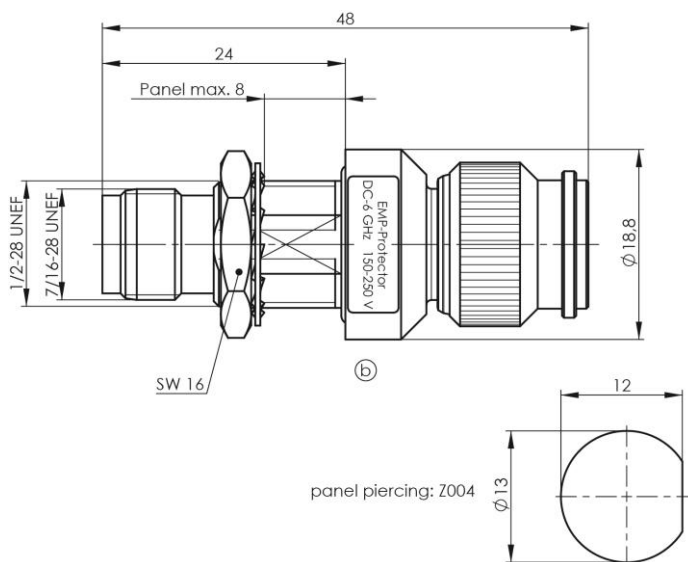

GPS Inline Amplifier



These inline amplifiers are capable of amplifying both L1 and L2 frequencies and will improve performance on receivers with cable lengths of over 15m (50ft). They're available with TNC connectors and no special wiring is required, making installation a breeze.

The amplifier is compatible with all dual frequency GPS receivers due to its wide operating voltage range, 3VDC to 28VDC, and low power consumption, 8mA. These amplifiers are made with gold plated brass with rugged and watertight packaging. Just plug the amplifier directly in line with your antenna cable. Power to the inline amplifier is already available from your GPS receiver.

The inline amplifier uses the same power as the antenna so no extra wiring is required.

General Information

- Inline Amplifiers with TNC connectors are 100mm in length, 16mm in diameter.
- Power consumption 8mA.
- Typical Noise figure for L1 Inline Amplifiers is <3 dB.
- Input voltage for all models is from 3 to 28 VDC. Current draw is <10mA .
- Operating temperature is -55°C to 85°C
- Relative humidity 0-100% condensing

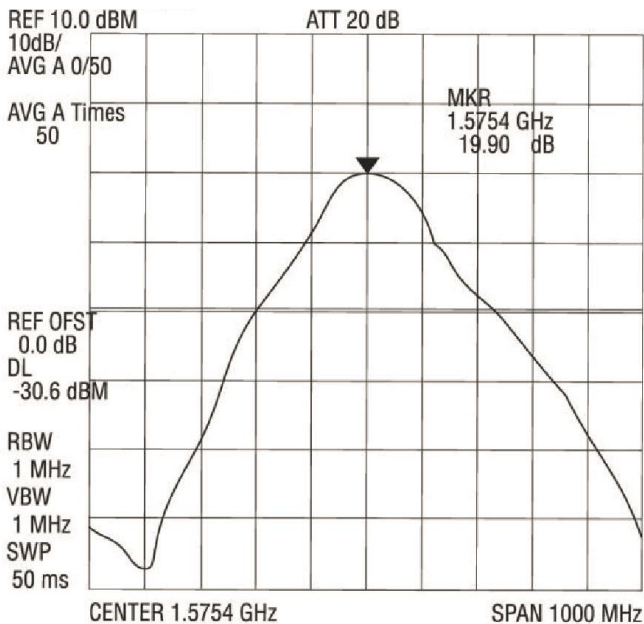

Typical Filtered Line Amp
Freq vs. Gain Plot

MASTER CLOCKS / TIME SERVERS / SOFTWARES / GNSS ELEMENTS



CABLES - ANTENNAS

The GPS cable is an essential and critical element of the time synchronization chain. Our low loss cable GPS reduces your installation costs (flexible cable, standard connector) while maintaining high performance.

Our cables can be associated with a line amplifier or a lightning protection.

Advantage

- Flexible cables
- Low loss (shell, strip + braid)
- Stability
- Standard connectors: TNC male - TNC male.

		SERIE LMR		
		LMR240	LMR400	LMR600
Impedance characteristics	W	50	50	50
Using frequency	DC-GHz	3.5	3.5	3.5
External diameter	mm	6.1	10.3	14.99
Insertion loss dB/meter	500 MHz	0.18	0.09	0.06
	1 GHz	0.26	0.13	0.08
	1.5 GHz	0.32	0.16	0.11
	2 GHz	0.37	0.19	0.12
	2.5 GHz	0.42	0.22	0.15
	3 GHz	0.46	0.24	0.16
	3.5 GHz	0.51	0.27	0.27
Number of shieldings		2	2	2
Static flexion radius	mm	19.1	25.4	38.2
Dynamic flexion radius	mm	63.1	100	152.4
Average admissible power	wcw à 2 GHz	170	370	590
Capacity	pF/m	79.4	78.4	76.6
Propagation speed	%	84	85	87
Shielding efficiency	dB	90	90	90
Dielectric strength	Veff	1500	2500	4000
Use temperature	°C	-40/+85	-40/+85	-40/+85
Rated mass	g/m	50	100	200

GNSS elements

(Global Navigation Satellite System)

MASTER CLOCKS / TIME SERVERS / SOFTWARES / GNSS ELEMENTS

		ITEM CODE							
		92225	/	<input type="text"/>	<input type="text"/>	<input type="text"/>	<input type="text"/>	<input type="text"/>	<input type="text"/>
				↑	↑	↑	↑	↑	
ANTENNA TYPE									
GPS	■	G							
GPS (Hardmount – only for 25 and 50 meters cable)	■	Q							
BEIDOU / GLONASS / GPS / GALILEO (Multi-constellation) white conical dome	■	B							
GPS Patch (5 m)	■	N							
without		0							
Cable type (LSZH*)									
LMR 240 (25m and 50m cable) cable	■	3							
LMR 400 cable	■	4							
*Low smoke, no halogen.									
Cable number									
1 cable	■					1			
2 cables	■					2			
Cable length of first cable									
without						00			
25 m	■					25			
30 m	■					30			
50 m	■					50			
80 m	■					80			
100 m	■					100			
Cable length of second cable									
without						00			
25 m	■					25			
30 m	■					30			
50 m	■					50			
80 m	■					80			
100 m	■					100			
OPTIONS									
Lightning Surge Arrestor (+ 10 m cable)	■								P
Inline Amplifier	■								A